

TAG-no.:	Dimensions (mm) / Weights (kg)	
---	DN	150
	L	350
	H	1410
	Weight - Valve	185

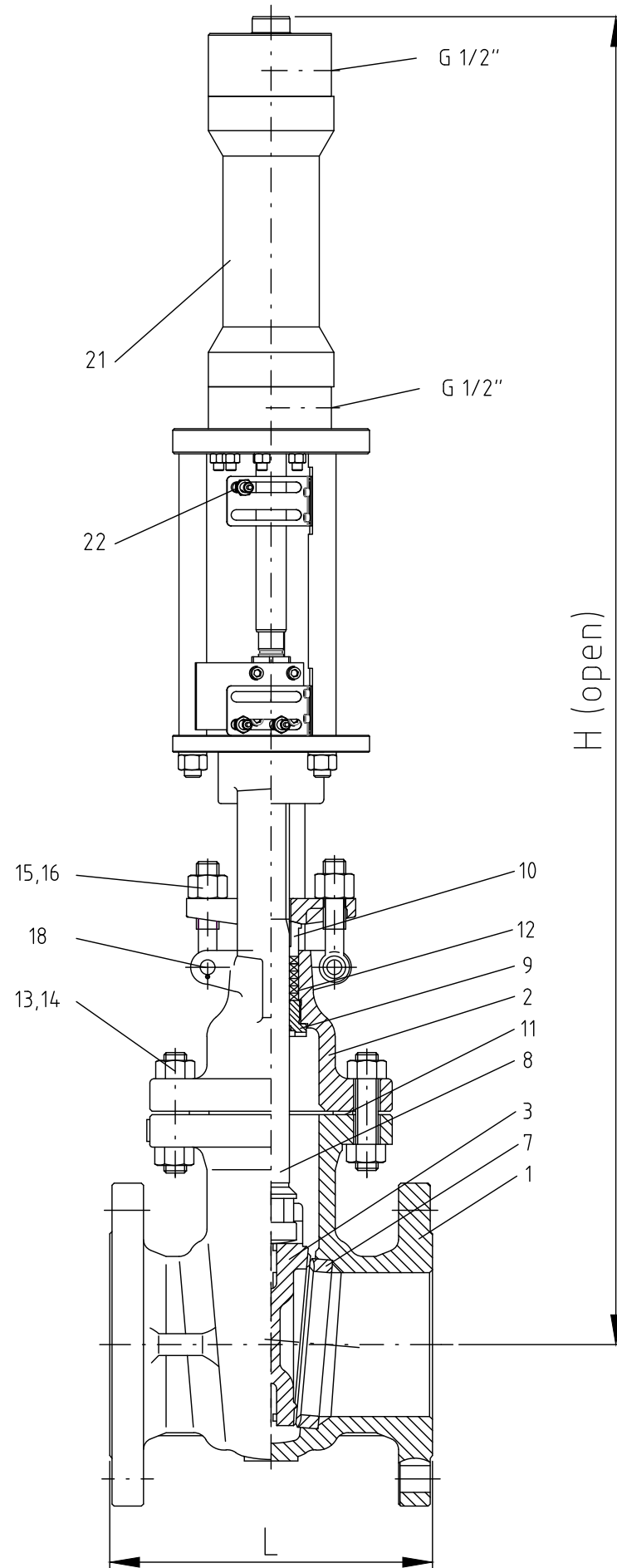

22	Position indicator	P+ F NBB4-12GM75-US
21	Hydraulic actuator	Steel + S.S.
18	Pin	Steel
16	Nut	ASTM A194 2H (1.1191)
15	Eyebolt	ASTM A193 B7 (1.7225)
14	Nut	ASTM A194 2H (1.1191)
13	Stud bolt	ASTM A193 B7 (1.7225)
12	Packing	Graphite
11	Gasket	Graphite + S.S.
10	Stuffing box	1.0619
9	Back seat	1.4006
8	Stem	1.4006
7	Seat ring	1.0460 + 13%Cr
3	Wedge	1.0619 + 13%Cr
2	Bonnet	1.0619
1	Body	1.0619

Marking acc.	EN19, CE acc. PED 2014/68/EU
Testing acc.	EN 12266-1/2
Flange ends acc.	EN 1092-1
FTF dimension acc.	EN 558 basic series 15

PROVALVE
Armaturen GmbH & Co. KG

PROVALVE Armaturen GmbH & Co. KG
Am Stadtberg 2a
D-39167 Niederdodeleben
Germany

**Gate valve with hydraulic actuator
DN150 PN25**

Rev.	Date	Created by	Checked by	Approved by	Brief Description
A	20.11.19	F. Müller	S. Schulz	R. Beyer	First issue

Customer:	Armatec
Purchase Order-no.:	77482
Project:	---
PROVALVE Ref.:	20190236488
Specification:	---
Item:	2
Figure-no.:	P03.013-Hydr
	A3