

Technical Datasheet

DIN Ball Valves 916N

JC
VALVES

The quality option

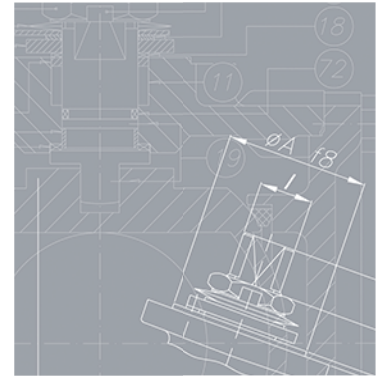

sales@jc-valves.com

www.jc-valves.com

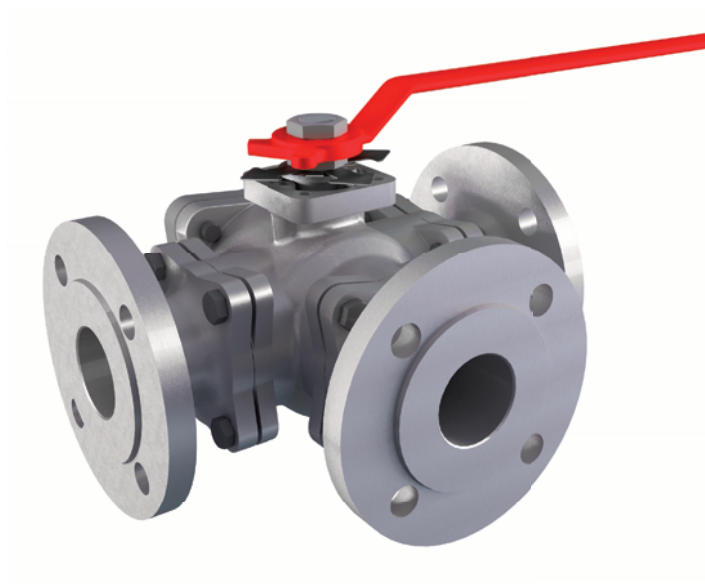

- Valve design: Full Bore EN 1983
- Body design: EN 12516
- Shell thickness: EN ISO 17292
- Flanges: DIN 2501 / EN 1092
- Face to face dimensions: EN 558 Series 27
- Marking: EN 19 / CE - PED
- Pressure testing: EN 12266
- Other: ATEX
- Shell finishing quality: MSS SP 55

Certifications

Company Certifications

- ISO9001 Quality Management System
- ISO14001 Environmental Management System
- AD2000-Merkblatt W0/A4
- API Monogram License 6D-0197, 600-0016

Product Certificates

- PED 2014/68/EU - CE marking
- ATEX 2014/34/EU- (II2GD)
- Russian Federation Certificate TRCU 10, TRCU 12, TRCU 32
- Food processing and pharmaceutical industry FDA, USP CLASS VI COMPLIANCE (CE 1935/2004)
- CRN (Canadian Registration Number)
- German type test certificate A216-16

DIN Ball Valves

F l o a t i n g

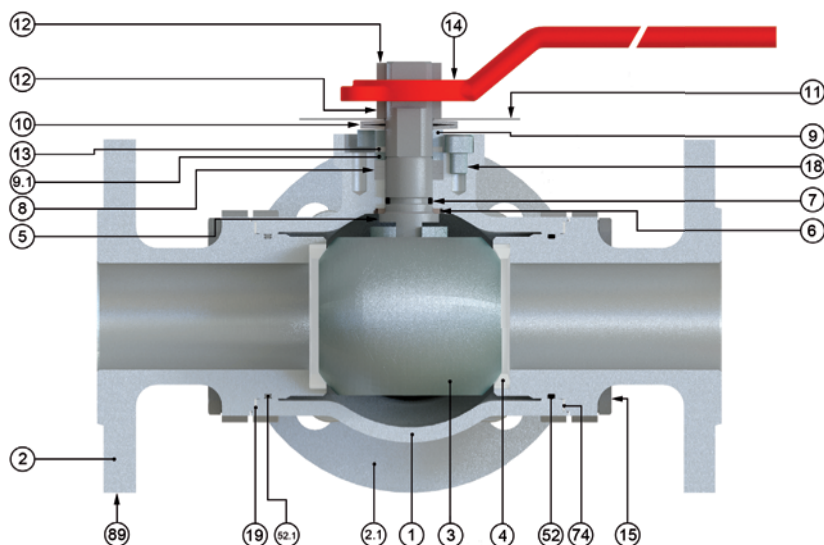

Other materials upon request

Item	Description	Material	
		A.I.T	I.I.T
1 / 2	Body / Body Connector	1.0619	1.4408
2.1	Side Cover	1.0619	1.4408
3	Ball	A 351 Gr. CF8M	
4	Seat ring	PTFE	
5	Stem	A 479 Type 316	
6	Stem thrust seal	25%GF PTFE	
7	O-ring	FKM	
8	Stem packing	Graphite	
9	Gland	AISI 303	AISI 316
9,1	Stop plate	F114	
10	Disk spring	E.N.P Carbon steel	
11	Look. Wash. Pointer	Rilsan coated Carbon St.	
12	Gland nut	Zinc plated carbon steel	AISI 303
13	Antifriction washer	25%GF. PTFE	
14	Wrench	EN-GJL-250	
15	Bolt	DIN 933 A4 - 70	
15.1	Bolt	DIN 933 A4 - 70	
18	Stop bolt	A4-70	
19	Body cover seal	PTFE	
52	O-ring	FKM	
52.1	O-ring	FKM	
74	Body connector seal	PTFE	
89	Identification plate	Stainless St.	

DIN Ball Valves

F l o a t i n g

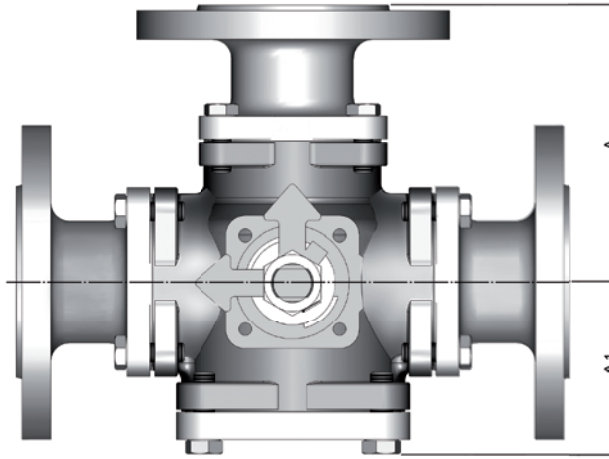
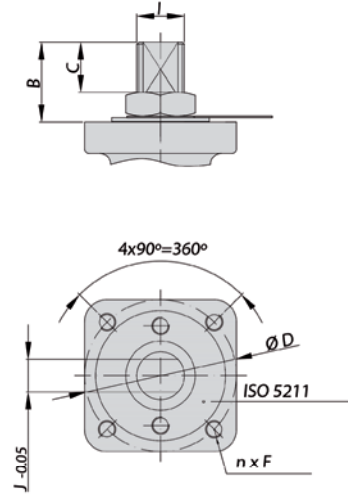
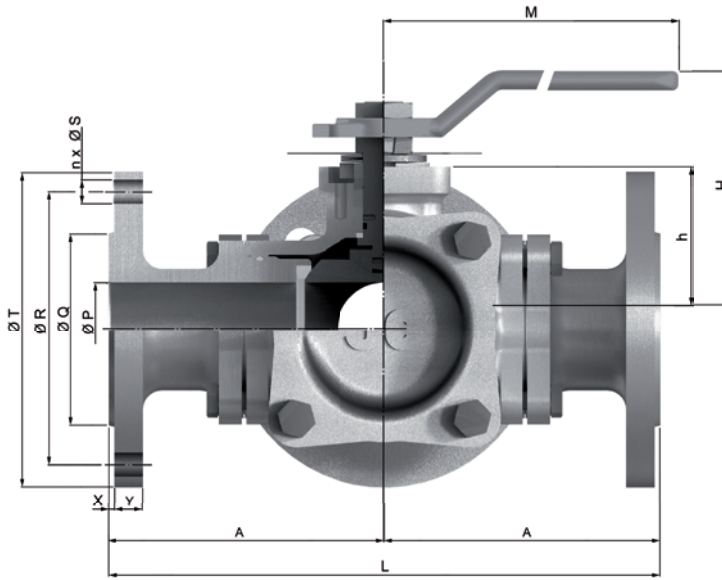

Note:
 Raised Face.- Rz: 12.5 - 50
 Acc. EN 1092-1:2001

* Weight in Kg * Dimensions in mm

Series 916 (PN 16)

DN	ØP	L	A	A1	H	h	M	ØT	ØR	ØQ	X	Y	n x ØS	WEIGHT	TORQUE
25	25	212	106	62	96	60	170	115	85	68	2	18	4x14	8	38
40	40	262	131	72	121	72	200	150	110	88	3	18	4x18	17	70
50	50	290	145	82	134	85	350	165	125	102	3	20	4x18	25	97
65	65	325	162,5	97	180	101	350	185	145	122	3	18	4x18	34	140
80	80	370	185	107	200	122	465	200	160	138	3	20	8x18	51	220
100	100	430	215	138	240	146	475	220	180	158	3	20	8x18	77	500
150	150	500	250	189	280	182	855	285	240	212	3	22	8x22	138	800
200	200	600	300	270	322	255	855	340	295	268	3	24	12x22	214	850

Free Stem Dimensions

DN	ISO 5211	B	C	ØD	n x F	l	J
25	F05	22	12,2	50	4xM6	M12x1.5	8
40	F07	33	19,2	70	4xM8	M18x1.5	12
50	F07	34	20,2	70	4xM8	M22x1.5	15
65	F10	34	19,2	102	4xM10	M22x1.5	15
80	F10	45	27,7	102	4xM10	M28x1.5	19
100	F12	59	32,2	125	4xM12	M36x1,5	24
150	F14	69	41	140	4xM16	M48x3	32
200	F14	69	67	140	4xM16	M48x3	32

Differential Pressure 16 bar

DN	BTO	RTO	ETO	BTC	RTC	ETC	MAST
15	-	-	-	-	-	-	-
20	-	-	-	-	-	-	-
25	23	12	14	17	12	18	27
32	-	-	-	-	-	-	-
40	59	30	35	44	30	47	92
50	70	35	42	53	35	56	174
65	110	55	66	83	55	88	174
80	146	73	88	110	73	117	355
100	360	180	216	270	180	288	734
125	-	-	-	-	-	-	-
150	680	340	408	510	340	544	1.740
200	920	460	552	690	460	736	1.740

Pressure – Temperature Charts

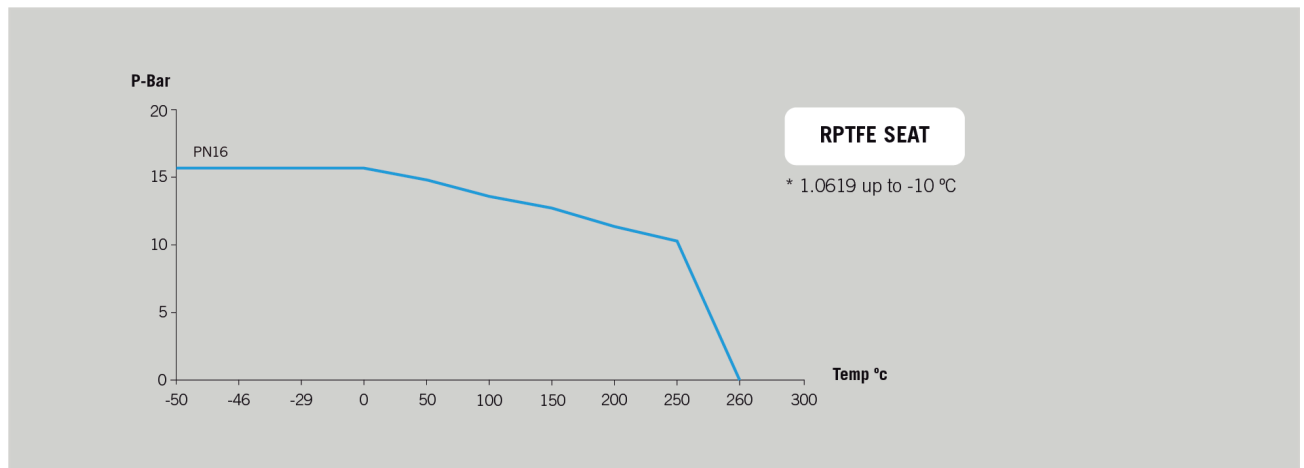
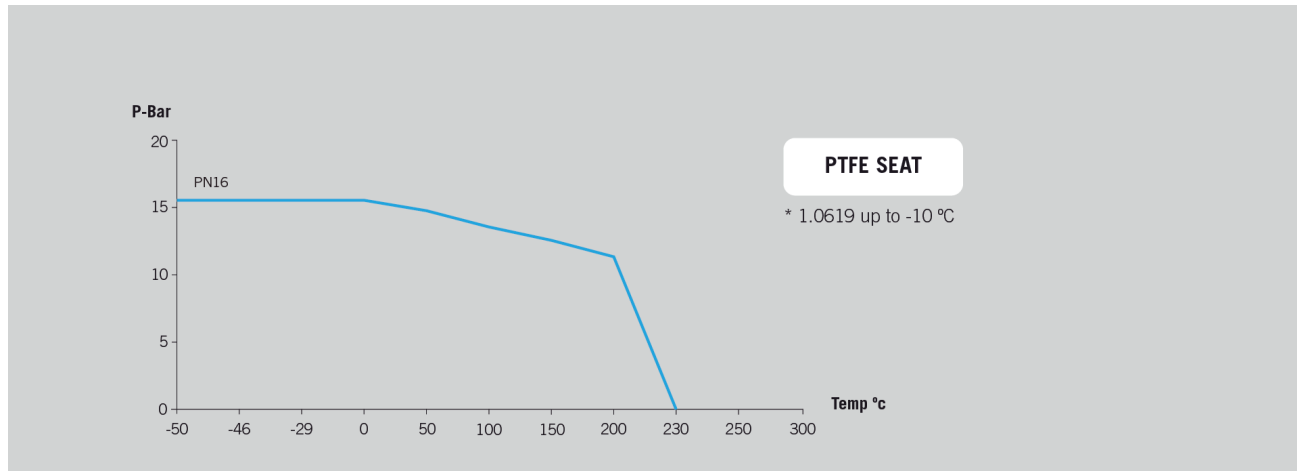

DIN Ball Valves

F l o a t i n g

3 WAY L PORT

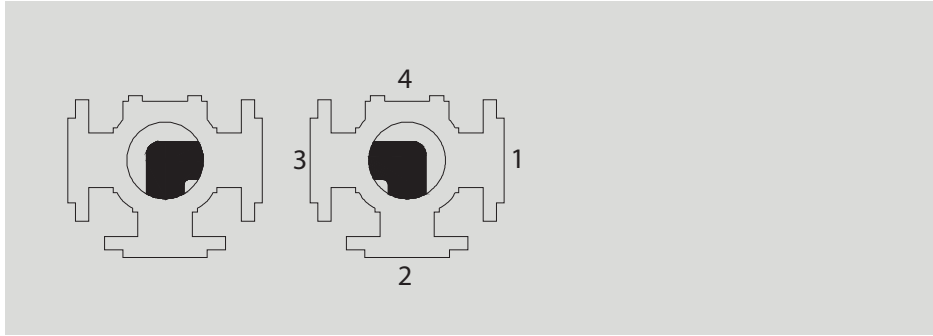

3 WAY T PORT

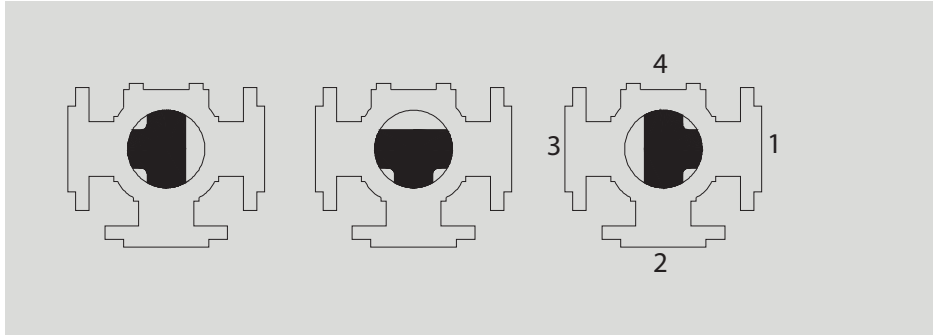

3 WAY INVERTED PORT

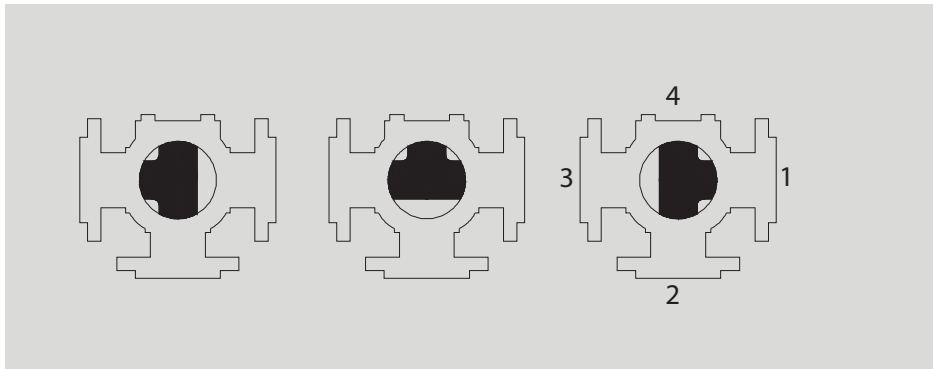

Kv Values in m³/h

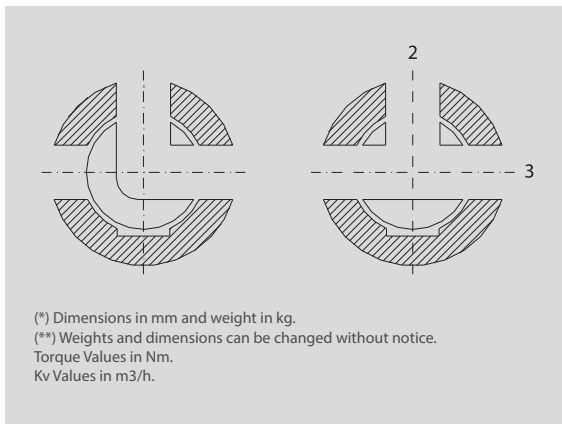

DN	PORT L	PORT T	
		PORT 2	PORT 3
25	24	22	54
40	58	59	154
50	78	80	264
65	140	142	496
80	282	316	746
100	376	378	1335
150	736	797	2583
200	1241	953	4408

DIN Ball Valves Flowing



Simple Stem Extension



Standard Stem Extension



Other Seat materials



Stainless Steel Lever

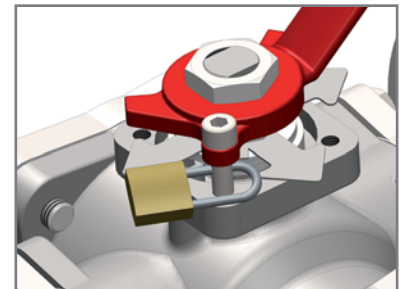

Locking Device

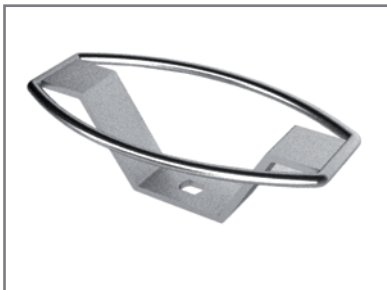

Oval Handwheel
Available from 1/2" to 2"



Manual and Declutchable
Gears

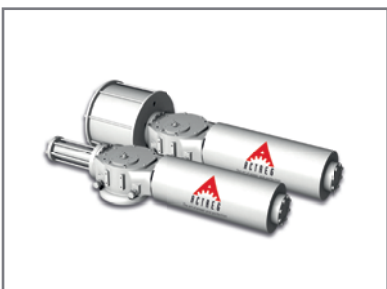

Pneumatic or Hydraulic
Scotch Yoke Actuators



Valve Automation option
available on Request