

DESIGN

Body	Double flanged type
End Connection	EN 1092 PN 25, 40 ASME B16.5 cl. 300 / B16.47 cl. 300 MSS SP 44 cl. 300
Face to Face	EN558-1/2 Series 14
Disc Seat	Replaceable
Shaft Seal Design	Stuffing box
Driving Shaft	With indicator for position of the disc
Special Design Options	-

TESTING PROCEDURES

Shell strength test	EN 12266-1, P10 DIN 3230, Part 3 API 598
Shell tightness test	EN 12266-1, P11 API 598
Seat tightness test	EN 12266-1, P12, Rate A/B ISO 5208, Rate A/B API 598
Operability test	EN 12266-2, F20 DIN 3230, Part 3 API 598

OPTIONS

Anti Static Design	In accordance with EN 736/3 and API 609
--------------------	-----------------------------------------

FUNCTIONAL CHARACTERISTICS

Application	On/off
Design pressure PS	Maximum 50 bar
Design temp. TS	-40°C (-40°F) to +250 °C (482 °F)
Flow velocity	5 m/s for liquids, 50 m/s for gases
Seat tightness rate	Bi-directional - ISO 5208 rate A (soft seated) Uni-directional – ISO 5208 rate B (metal seated)

MARKING & CERTIFICATION

Marking	EN 19, MSS SP 25
Certification	EN 10204 - 2.2, 3.1, 3.2
PED	Categorie III

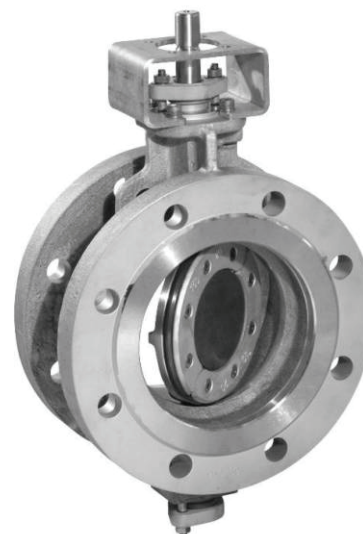
**PRODUCT DATA**

General Description	BUTTERFLY VALVE - High Performance double excentric
Design Code	EN 593
Size Range	DN 50 - 600, NPS 2" - 24"
Maximum Pressure	20 bar

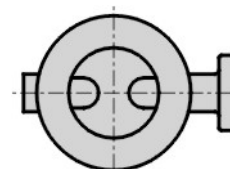
PREFERRED POSITION WHEN INSTALLED IN HORIZONTAL PIPELINE

PARTS LIST – DYNAXE F142 – 50-600 (2"-24")

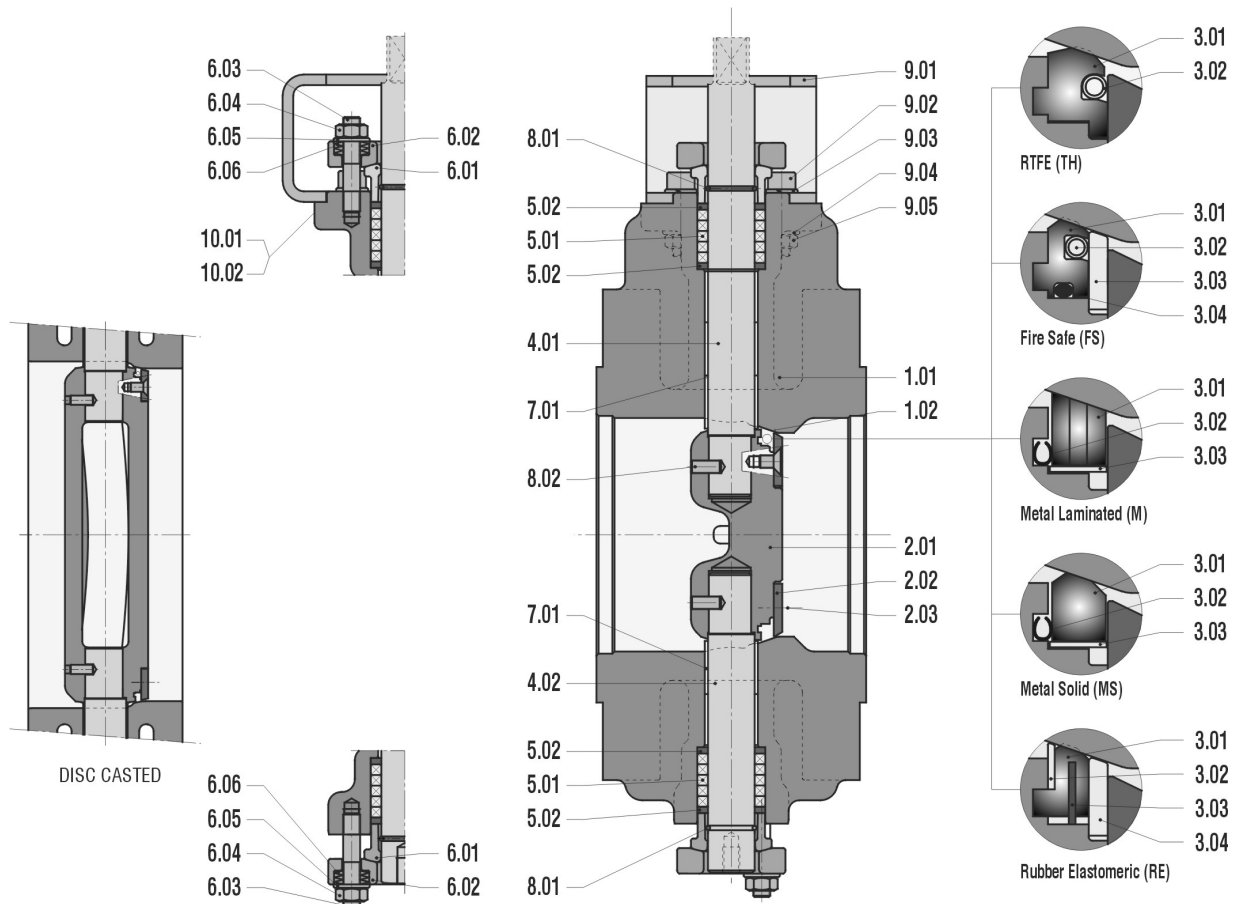

ITEM	DESCRIPTION	MATERIAL ⁽¹⁾	EN/DIN	COMPARABLE ASTM
1.01	Body	Austenitic SS Carbon Steel	1.4408, EN 10213 1.06019, EN 10213	A 351, CF8M A 216, WCB
1.02	Body seat	Stainless steel Stellite	1.4370	-
2.01	Disc	Austenitic SS ⁽²⁾ Carbon Steel ⁽³⁾	1.4401, EN 10088 1.0460, EN 10273	A 182, F316 A 105 N
2.02	Retaining ring	Austenitic SS	1.4401, EN 10088	A 182, F316
2.03	Screw	Stainless Steel – A4/70		
3.01	Disc seat ring (TH)	RTFE 15-12-3	-	-
3.02	Helix coil	Austenitic SS	1.4401, EN 10088	A 182, F316
4.01	Upper shaft	Austenitic SS Martensitic SS	1.3964 1.4021, EN 10088	A 479, XM-19 A 276, 420
4.02	Lower shaft	See ITEM 4.01	See ITEM 4.01	See ITEM 4.01
5.01	Packing ring	Graphite (>99.85%)		
5.02	Taper ring	Austenitic SS	1.4401, EN 10088	A 182, F316
6.01	Packing gland	Austenitic SS	1.4408, EN 10213	A 351, CF8M
6.02	Gland flange	Austenitic SS	1.4408, EN 10213	A 351, CF8M
6.03	Stud bolt	Stainless Steel – A4/70		
6.04	Hex. nut	Stainless Steel – A4/70		
6.05	Washer	Stainless Steel – A4		
6.06	Beveled washer	Stainless Steel		
7.01	Sliding bearing	Austenitic SS / coated	1.4401, EN 10088	A 182, F316
8.01	Snap ring	Stainless Steel	1.4310	
8.02	Set screw	Stainless Steel – A4/70		
9.01	Bracket	Austenitic SS	1.4401, EN 10088	A 182, F316
9.02	Screw	Stainless Steel – A4/70		
9.03	Washer	Stainless Steel – A4		
9.04	Spring lock washer	Stainless Steel – A4		
9.05	Hex. nut	Stainless Steel – A4/70		
10.01	Marking plate	Austenitic SS	1.4401, EN 10088	A 182, F316
10.02	Blind rivet	Stainless Steel – A4		

⁽¹⁾ Other materials like Duplex, 6Mo, Titanium, on request

⁽²⁾ forged ≤ DN 200, casted ≥ DN 250, material 1.4408, EN 10213 (A 351, CF8M)

⁽³⁾ forged ≤ DN 200, casted ≥ DN 250, material 1.0619, EN 10213 (A 216, WCB)

DIMENSIONS – DYNAXE F142 – 50-600 (2"-24") ⁽⁴⁾

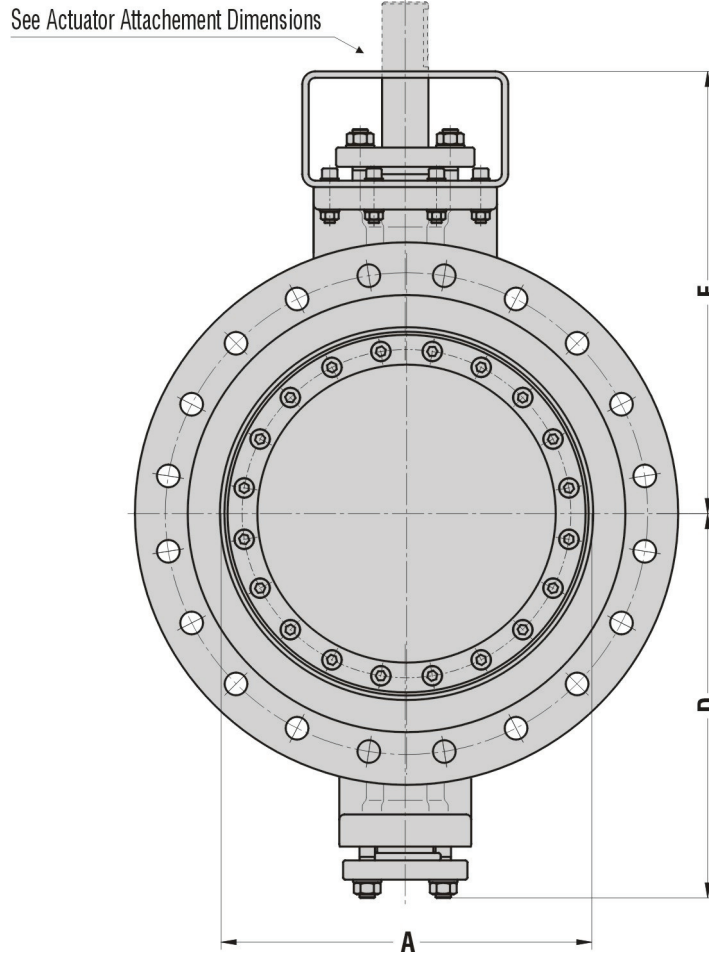
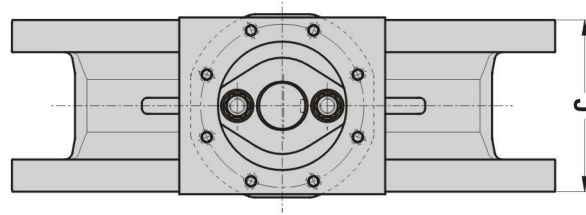

DN	NPS	A	C	D	E	MASS ±kg
50	2"	58	43	139	197	
65	2½"	58	46	139	197	
80	3"	71	64	157	204	
100	4"	96	64	170	216	
125	5"	120	70	202	263	
150	6"	150	76	217	278	
200	8"	197	89	252	307	
250	10"	251	114	319	388	
300	12"	301	114	343	413	

DN	NPS	A	C	D	E	MASS ±kg
350	14"	323	127	441	473	
400	16"	372	140	495	585	
450	18"	425	152	521	611	
500	20"	477	152	550	642	
600	24"	559	178	640	728	

⁽⁴⁾ Other sizes on request